



*International  
Virtual  
Observatory  
Alliance*

## **STC-X: Space-Time Coordinate (STC) Metadata XML Implementation**

**Version 1.00**

***IVOA Note 15 March 2005***

**This version:**

<http://www.ivoa.net/Documents/Notes/STC-X/STC-X-20050315.html>

**Latest version:**

<http://www.ivoa.net/Documents/latest/STC-X.html>

**Previous version(s):**

None

**Author:**

A. H. Rots

---

### **Abstract**

The XML implementation of the Space-Time Coordinate (STC) metadata is described through UML-like diagrams.

## Status of This Document

This is a Note. The first release of this document was 15 March 2005.

*This is an IVOA Note expressing suggestions from and opinions of the authors. It is intended to share best practices, possible approaches, or other perspectives on interoperability with the Virtual Observatory. It should not be referenced or otherwise interpreted as a standard specification.*

A list of [current IVOA Recommendations and other technical documents](http://www.ivoa.net/Documents/) can be found at <http://www.ivoa.net/Documents/>.

## Acknowledgements

The diagrams were created using Altova's XMLSpy.

## Contents

1	Introduction	3
2	Top-level Metadata Elements	4
2.1	STCmetadata	4
3	Coordinate Systems	5
3.1	CoordSys	5
3.2	AstroCoordSys	6
3.3	PixelCoordSys	6
4	Coordinate Frames	7
4.1	TimeFrame	7
4.2	SpaceFrame	8
4.3	SpectralFrame	8
4.4	RedshiftFrame	9
4.5	GenericCoordFrame and PixelCoordFrame	9
5	Coordinate Frame Components	10
5.1	SpaceRefFrame	10
5.2	ReferencePosition	11
5.3	CoordFlavor	12
6	Coordinates	13
6.1	Coords	13
6.2	AstroCoords	14
6.3	Coordinate	15
6.4	ScalarCoordinate	16
6.5	AstronTime	17

## STC-X

6.6	SpatialPosition	18
6.7	astroCoordsFileType	19
7	Coordinate Area	20
7.1	CoordArea	20
7.2	PixelCoordArea	20
7.3	SpatialInterval	21
8	Coordinate interval	22
8.1	CoordInterval	22
9	Spatial Region	23
9.1	Negation, Union, Intersection	23
9.2	Allsky, Circle, and Ellipse	24
9.3	Polygon, Box, and Sector	25
9.4	Convex and Convex Hull	26
10	Changes from Previous Versions	27
	References	27

## 1 Introduction

In this Note the XML implementation of the Space-Time Coordinate metadata (STC) is illustrated through the UML-like diagrams created by XMLSpy.

The corresponding XML schemata may be found at:

- <http://www.ivoa.net/xml/STC/v1.20>  
<http://hea-www.harvard.edu/~arots/nvometa/v1.2/stc-v1.20.xsd>  
is the top-level schema of the XML implementation STC-X, containing the coordinate system and coordinate area definitions.
- <http://www.ivoa.net/xml/STC/STCcoords/v1.20>  
<http://hea-www.harvard.edu/~arots/nvometa/v1.2/coords-v1.20.xsd>  
is the STC-X schema with the coordinate value definitions.
- <http://www.ivoa.net/xml/STC/STCregion/v1.20>  
<http://hea-www.harvard.edu/~arots/nvometa/v1.2/region-v1.20.xsd>  
is the STC-X schema for the *region* specification.

The definition of STC and the linear string implementation STC-S (based on the current document) are referenced at the end of this document.

## 2 Top-level Metadata Elements

### 2.1 STCmetadata

There are currently four types of STCmetadata elements derived, all based on the stcDescriptionType consisting of three elements: CoordSys, Coords, and CoordArea.

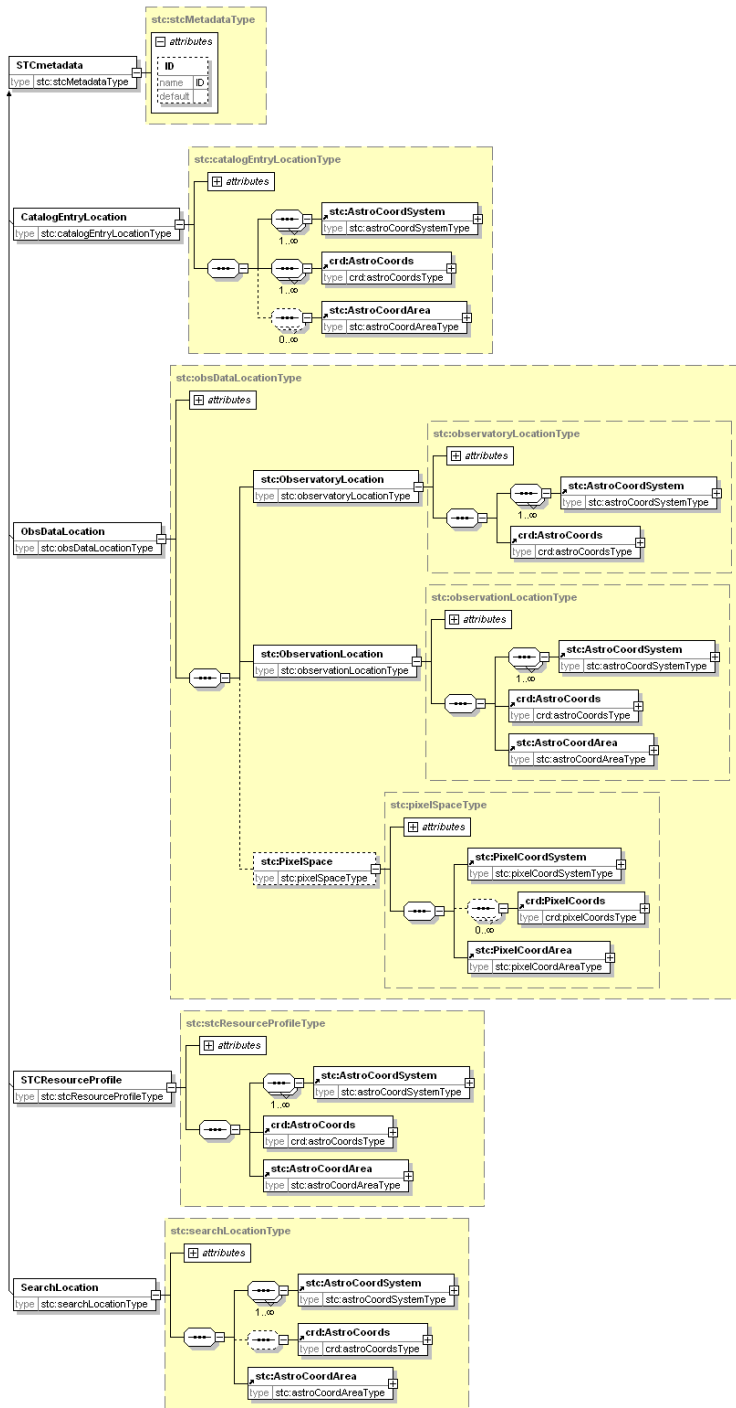

### 3 Coordinate Systems

#### 3.1 CoordSys

Basic CoordSys contains one or more CoordFrames and is required to have an ID.

There are 5 specific Frame implementations and 1 generic Frame. There are two specific coordinate systems derived from CoordSys: AstroCoordSystem and PixelCoordSystem.

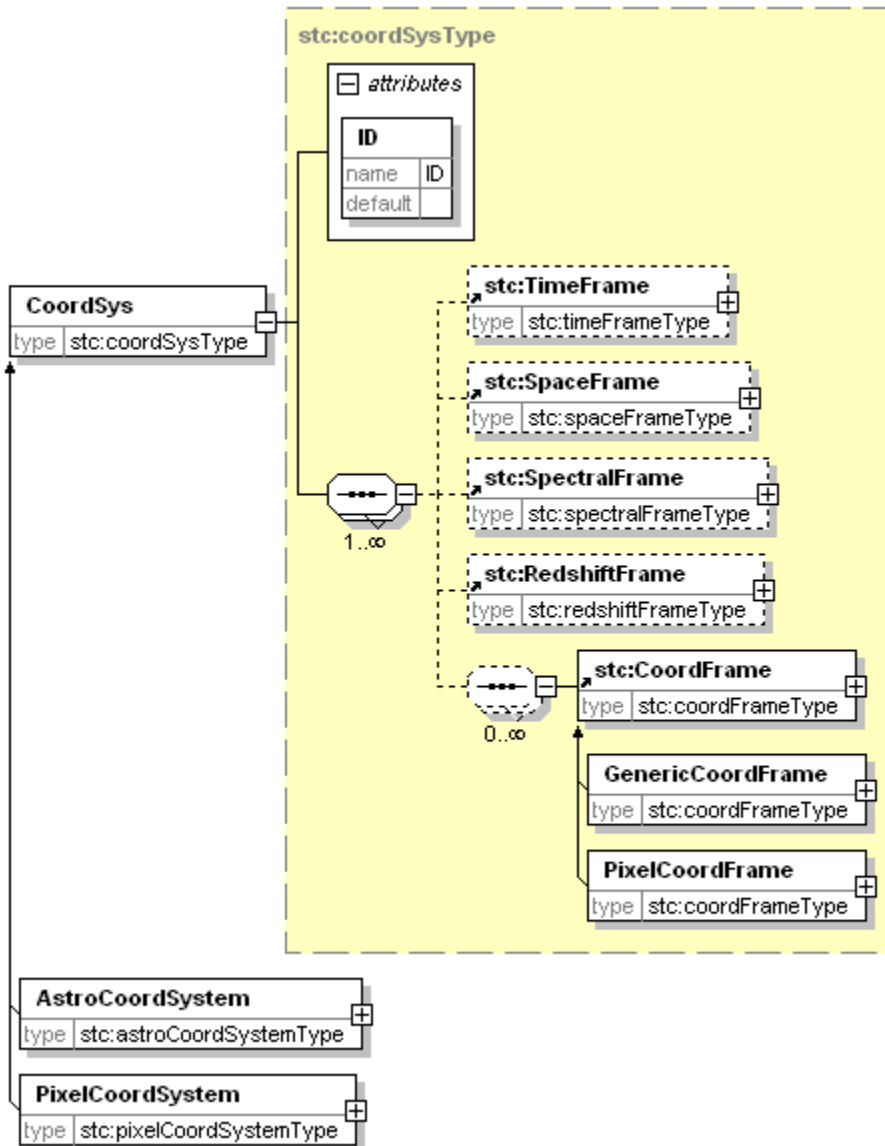

### 3.2 AstroCoordSys

AstroCoordSystem contains 3 required Frames, an optional Frame, and may contain any number of generic Frames.  
It is derived from coordSysType by restriction.

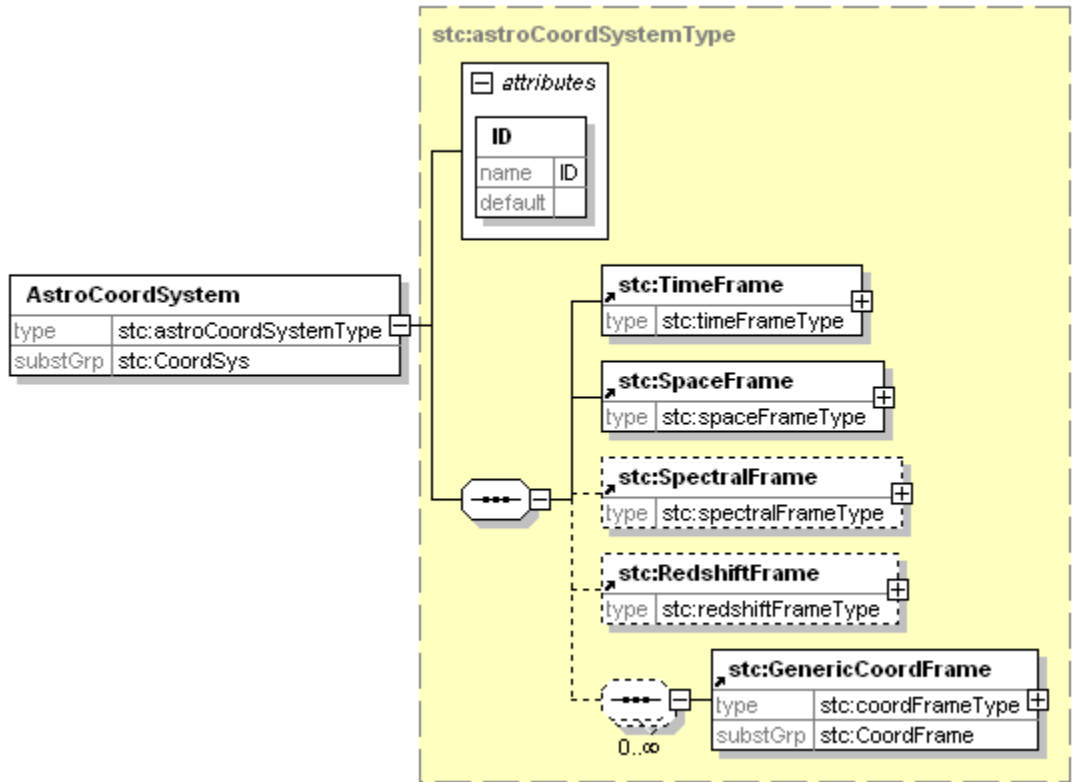

### 3.3 PixelCoordSys

PixelCoordSystem is made up of Frames that only have a name

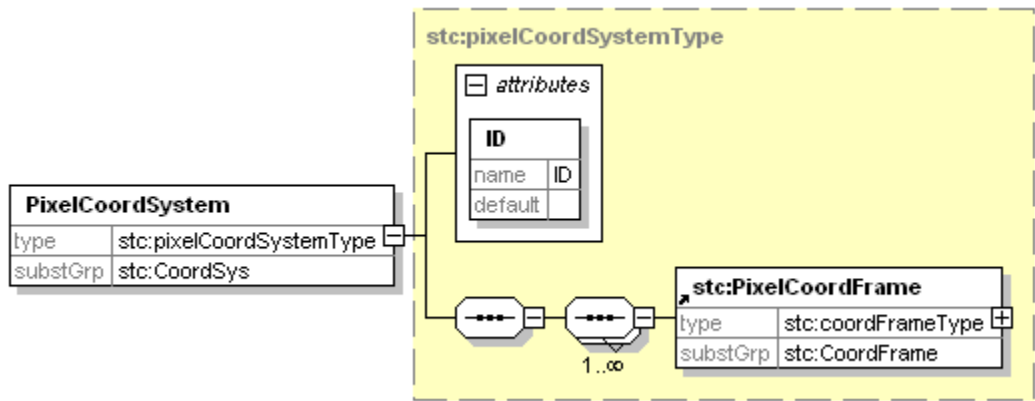

## 4 Coordinate Frames

### 4.1 TimeFrame

The TimeFrame:

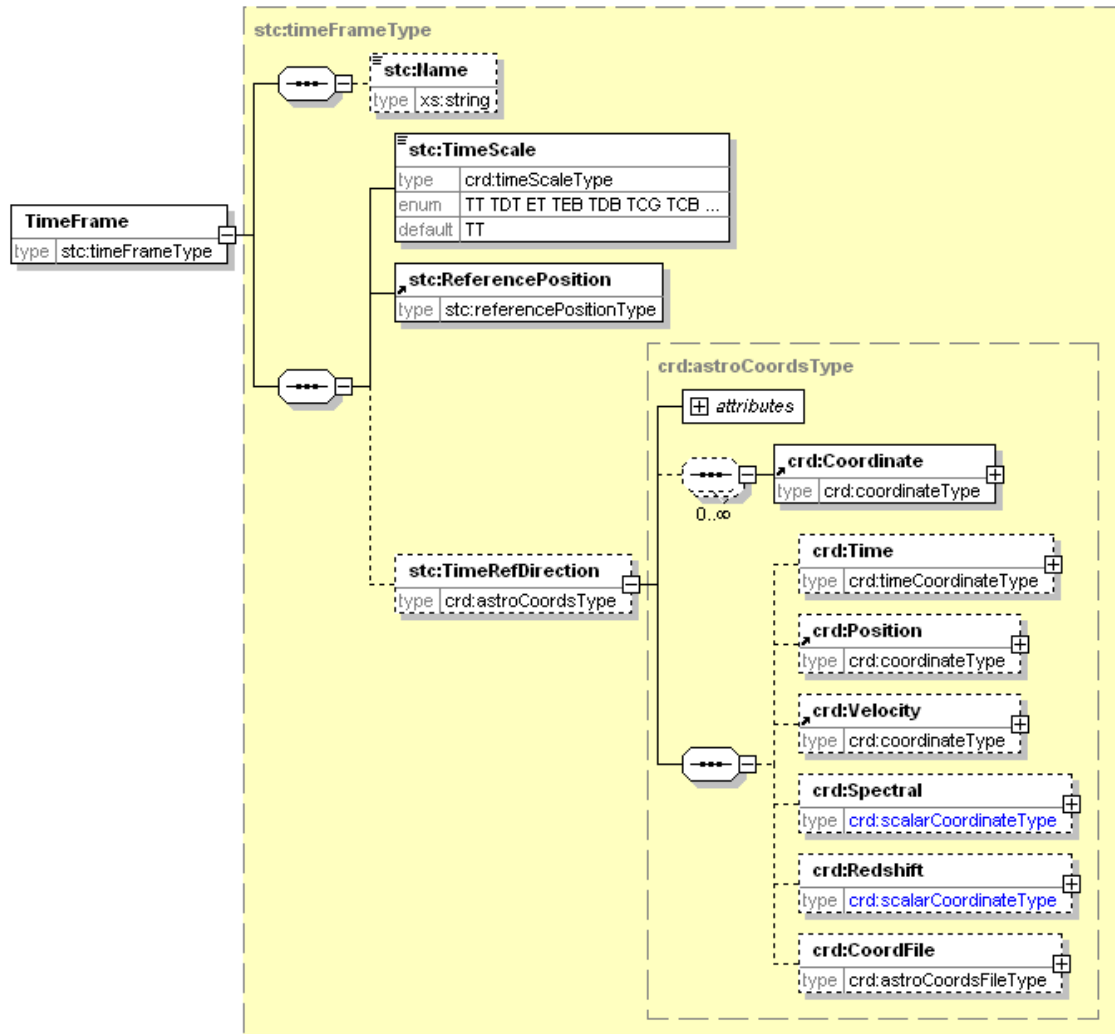

### 4.2 SpaceFrame

The OffsetCenter is added to accommodate lists with RA and Dec offsets. Note that this is intended for pure numeric RA and Dec offsets; true angle offsets should be handled through a CustomSpaceRefFrame.

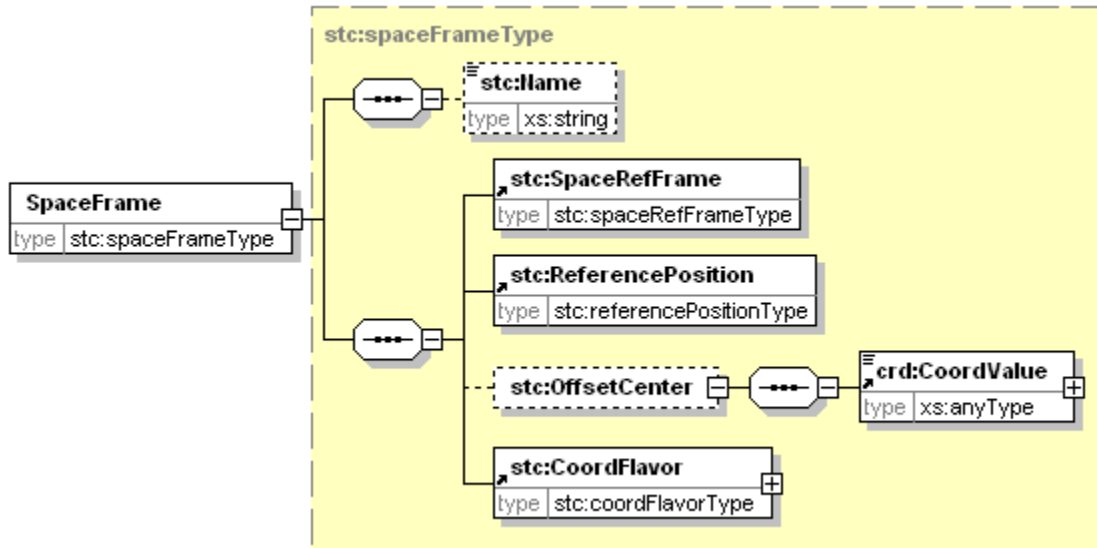

### 4.3 SpectralFrame

The SpectralFrame is simple:

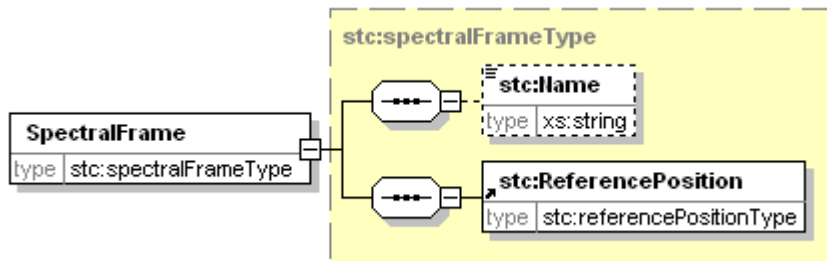

#### 4.4 RedshiftFrame

The RedshiftFrame has a little more:

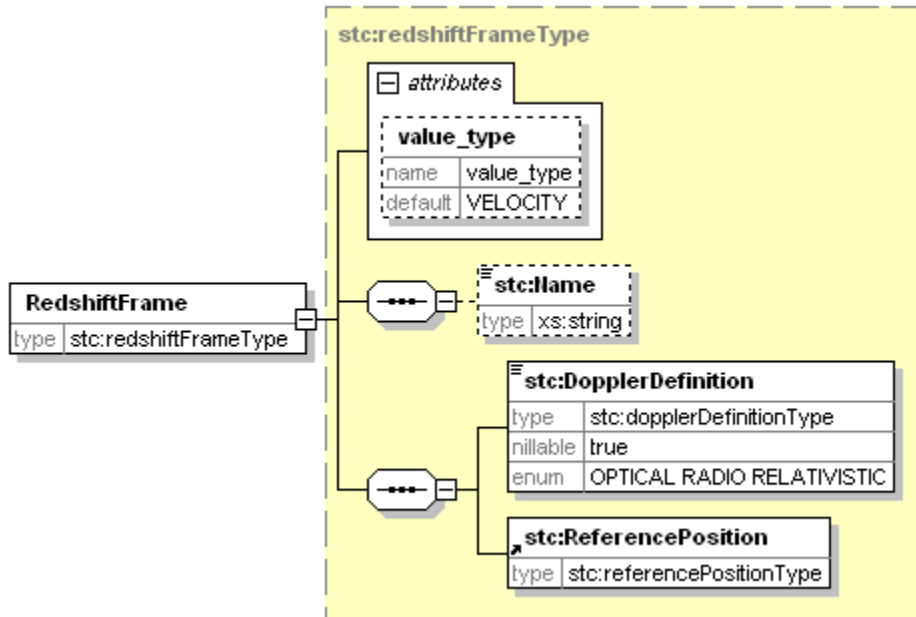

#### 4.5 GenericCoordFrame and PixelCoordFrame

The GenericCoordFrame (and PixelCoordFrame) just have a name:

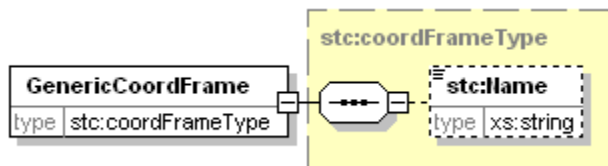

## 5 Coordinate Frame Components

### 5.1 SpaceRefFrame

The SpaceReferenceFrame (part of SpaceFrame) uses the names of the elements in the SpaceRefFrame substitution group to identify the frame, rather than using a single element with enumerated values; this makes it easier to extend the list – by just adding members to the substitution group – such as solar reference systems.

Note that ICRS does not have an Equinox element. The figure below is truncated.

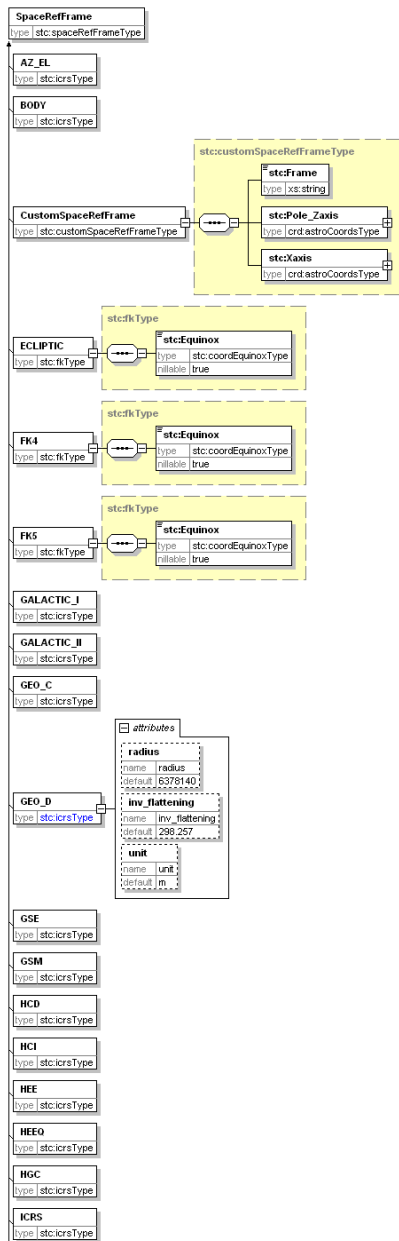

## 5.2 ReferencePosition

The ReferencePosition uses the same technique:

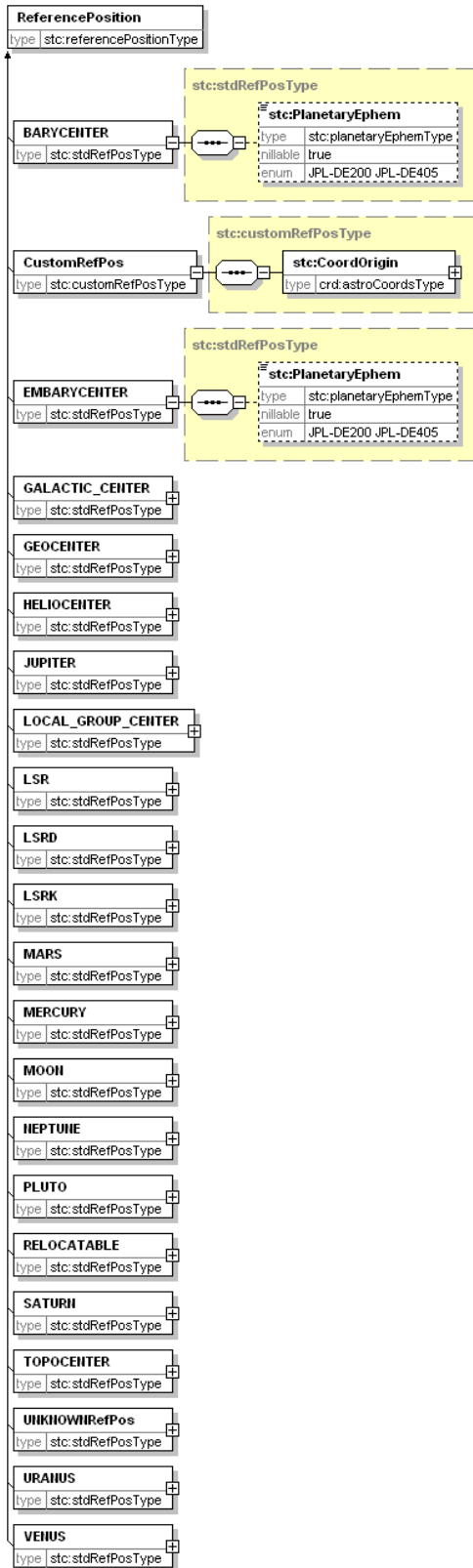

### 5.3 CoordFlavor

The CoordFlavor also determines the flavor by the names of the substitution group's elements and is similarly easily extensible.

In addition, these elements have two attributes: the number of axes (coord\_naxes, default 2) and a Boolean indicating whether velocities are present (coord\_vel, default false)

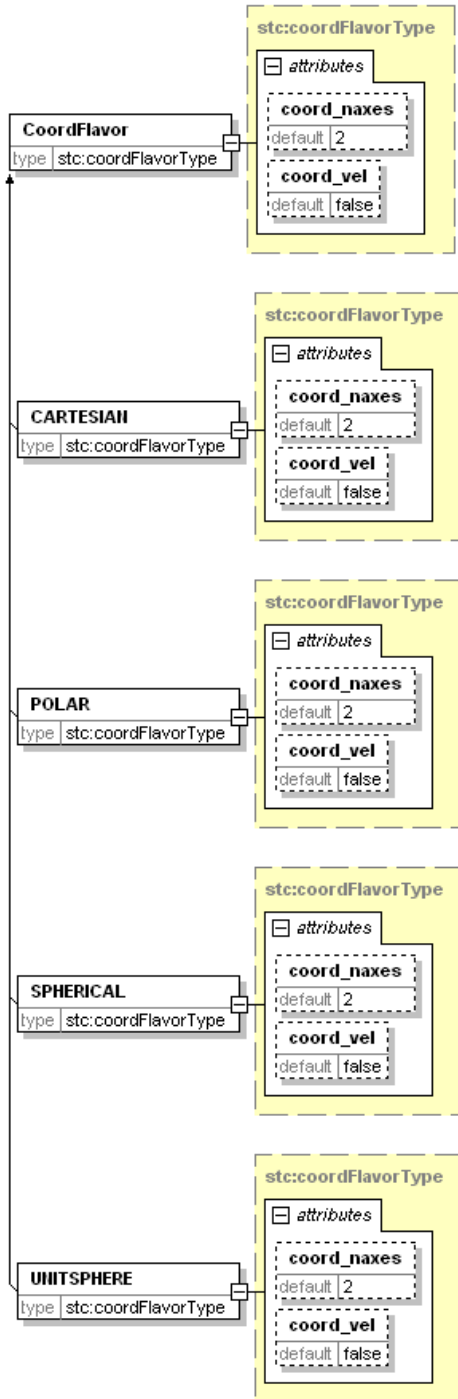

## 6 Coordinates

### 6.1 Coords

Coords is the generic coordinates element. It needs to refer to a specific instance of a CoordSys.

There are two derived classes: AstroCoords (by extension) and PixelCoords (by restriction).

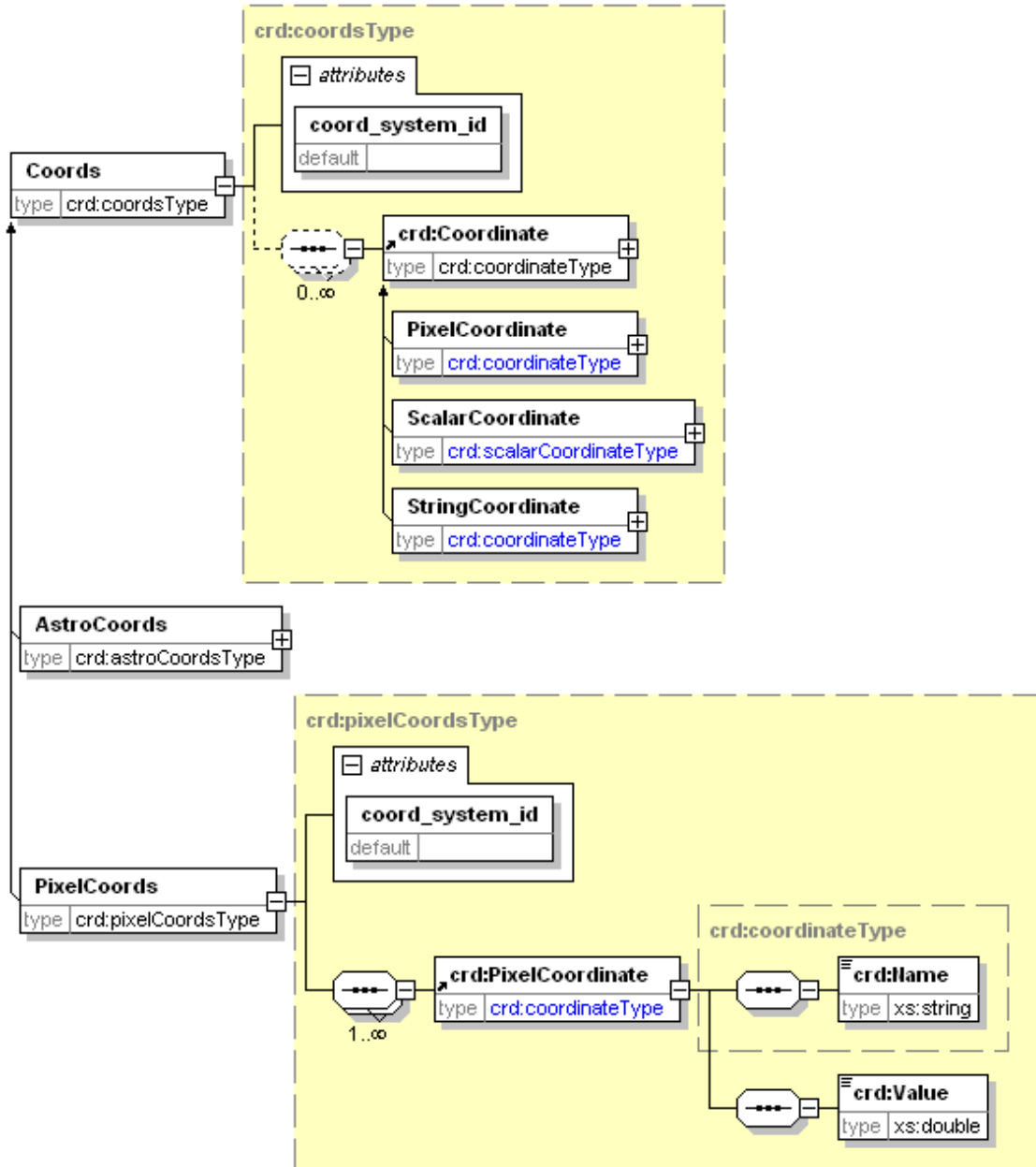

## 6.2 AstroCoords

AstroCoords contains specific astronomical coordinates (time, space, spectral, redshift) and, optionally, generic coordinates

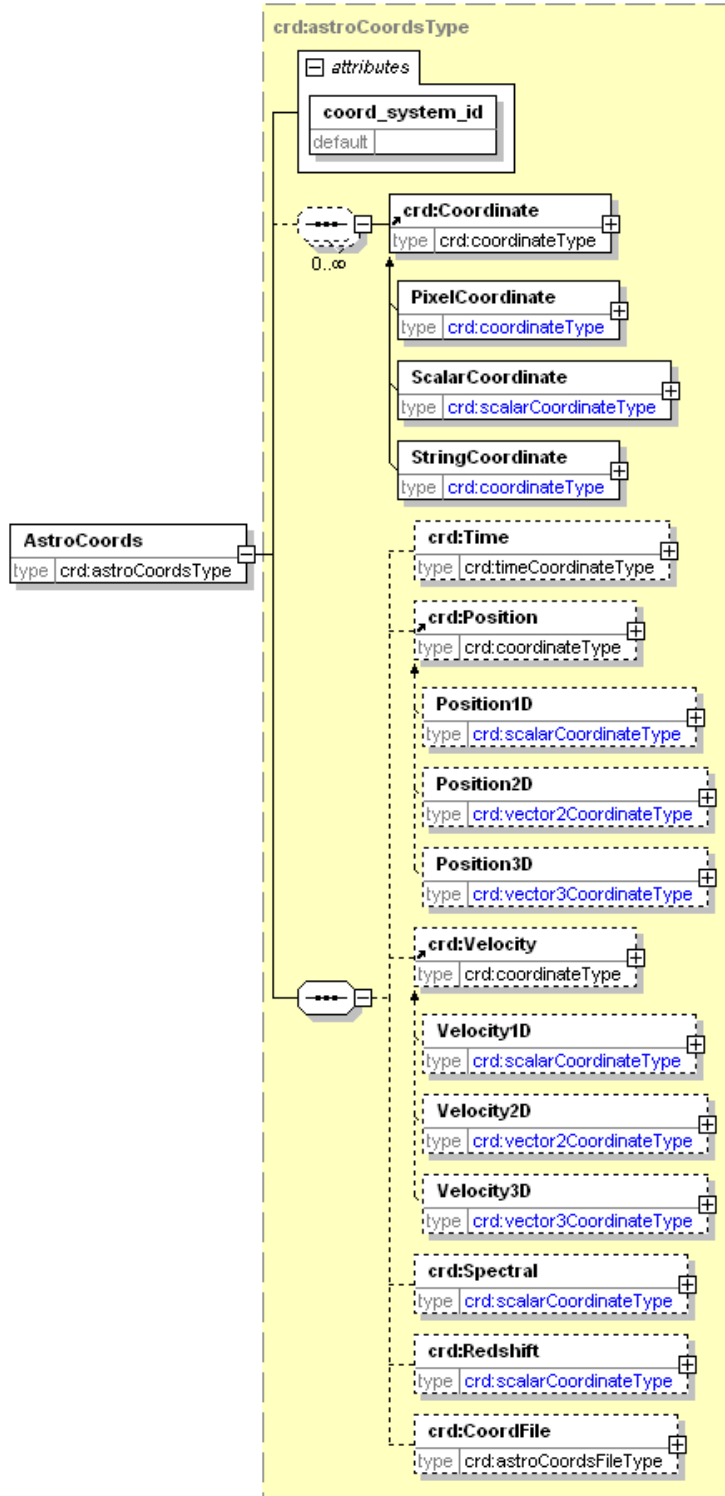

### 6.3 Coordinate

The simple Coordinate just has a Name. Its simplest derived classes add only a Value (PixelCoordinate) or a Values and an optional Unit (StringCoordinate). ScalarCoordinate is the generalized full coordinate type.

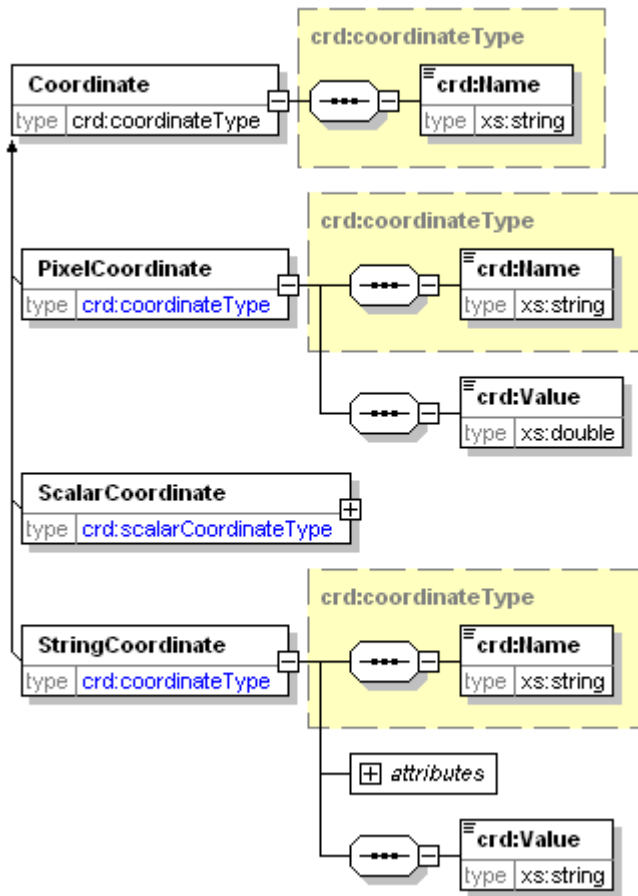

## 6.4 ScalarCoordinate

ScalarCoordinate, in addition to the Name, has an optional Unit and the full 5 coordinate components (Value, Error, Resolution, Size, and PixelSize), each of which may be an actual value or an IDREF pointing to another element in the document. Not all components need to be present, but at least one of them ought to. Note that components other than Value may appear in pairs, which would indicate a range.

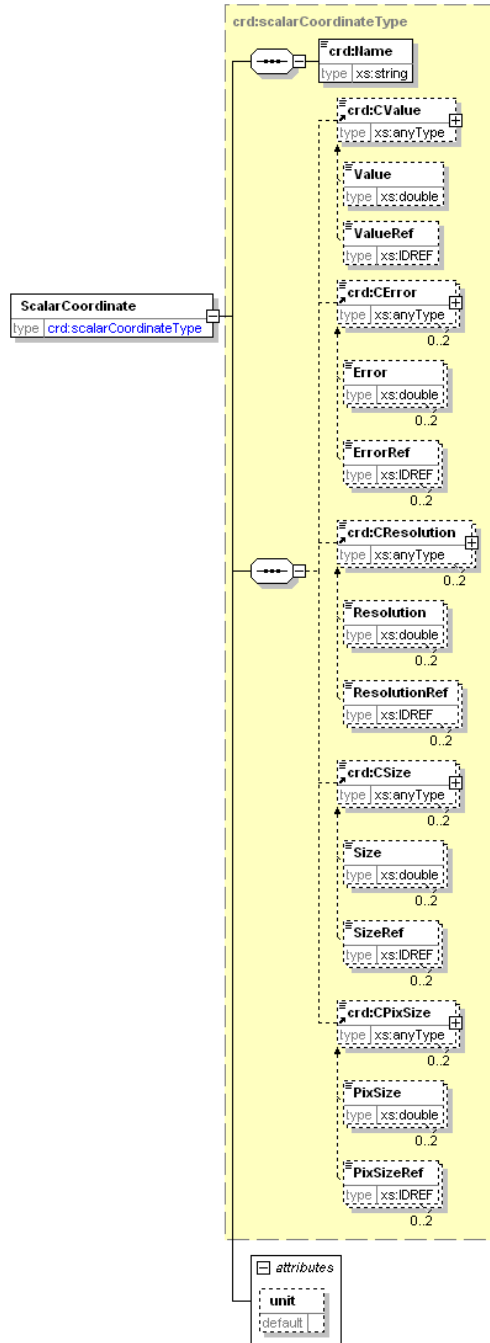



## 6.6 SpatialPosition

Spatial Position is more complicated Coordinate type since it refers to a compound axis; i.e., it may be 1-, 2-, or 3-dimensional.

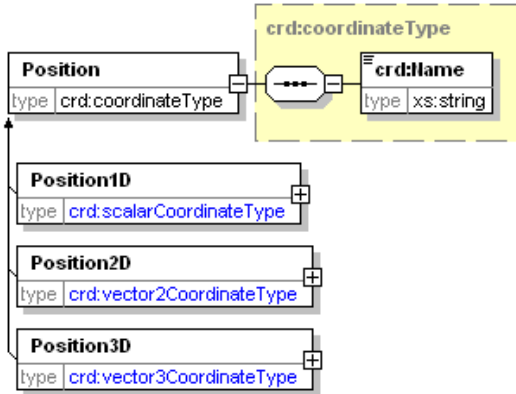

In particular, the multi-dimensional components other than Value are more complicated. Value would be a vector of 3 doubles in Position3D, but the others might include additional position angles or might be formally expressed by a 3x3 matrix. The attributes of a position angle provide its units as well as its definition.

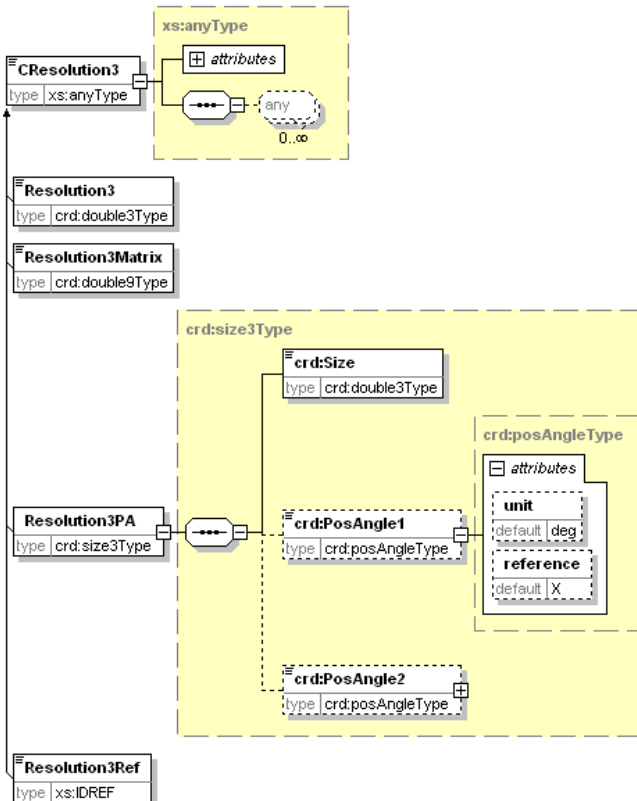

## 6.7 astroCoordsFileType

Coordinates in a FITS file:

The AstroCoords element may refer to a specific binary table HDU in a FITS file (specified through FITSFile, derived from anyURI), identifying the columns in which individual coordinate components are contained.

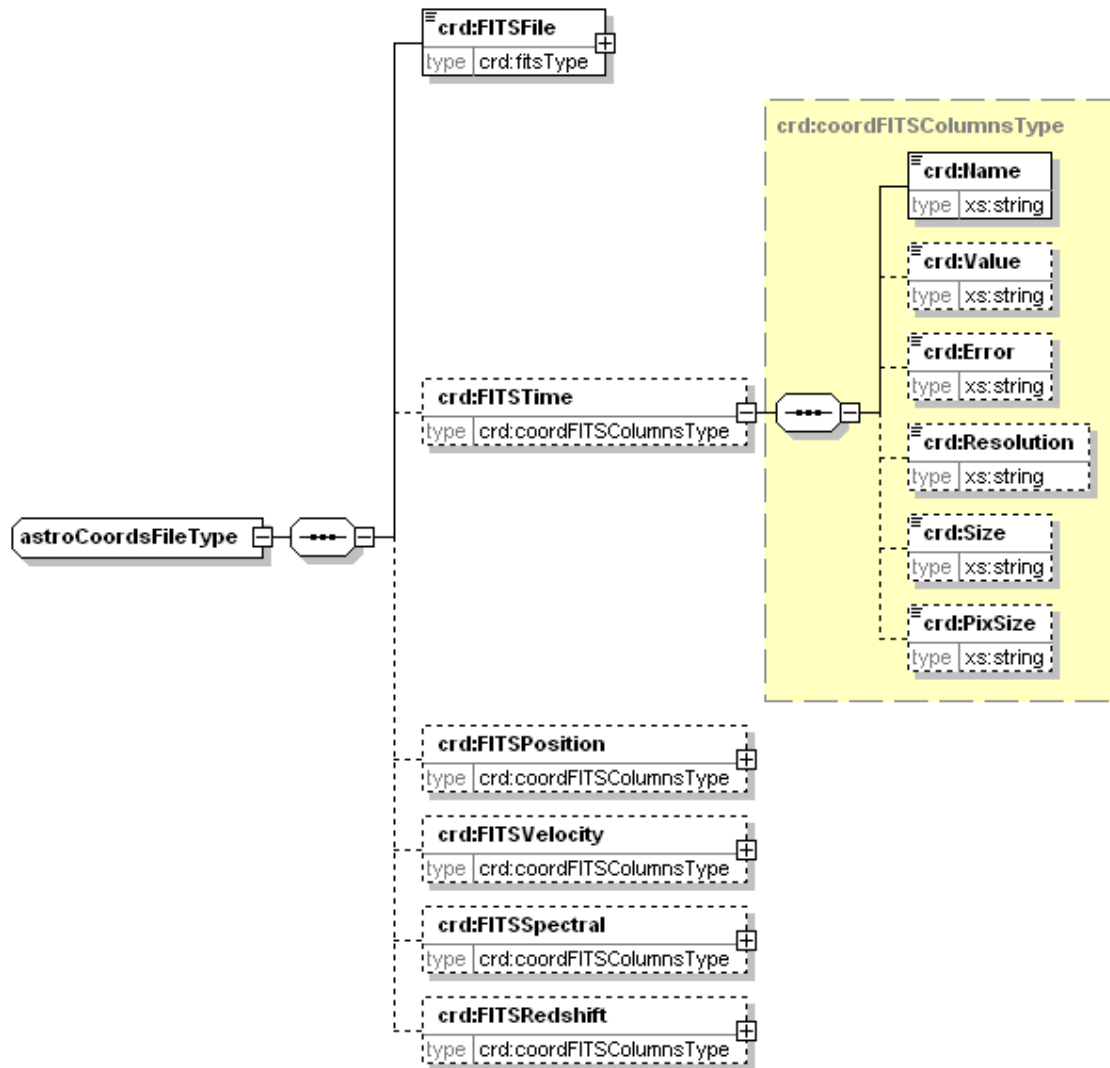

## 7 Coordinate Area

### 7.1 CoordArea

CoordArea specifies the volume in coordinate space that is occupied by the object to which the STC metadata is attached. It requires an IDREF pointing to a CoordSys. An area may consist of multiple intervals along each axis. Intervals have a FillFactor.

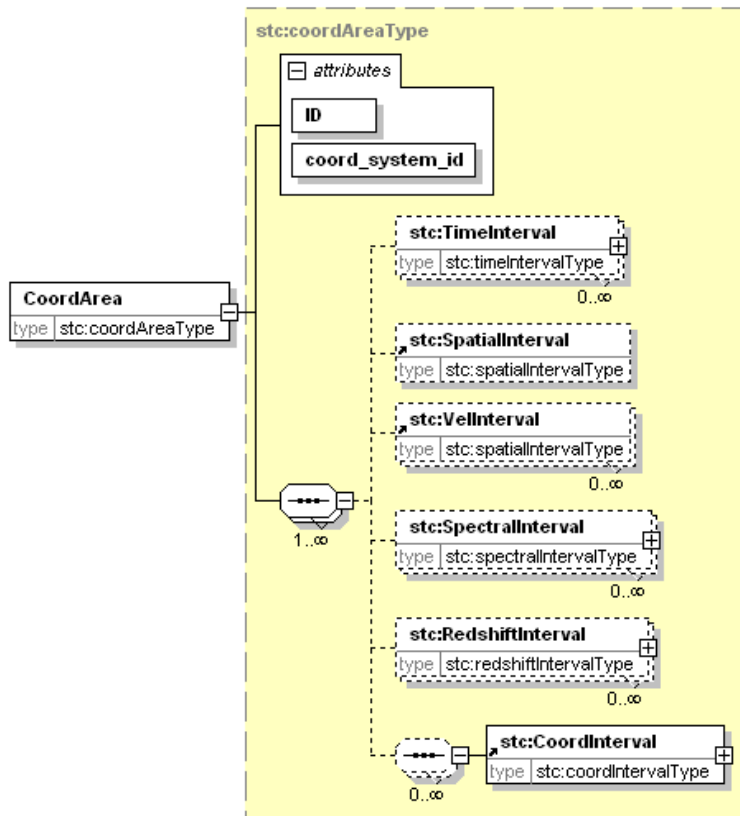

### 7.2 PixelCoordArea

PixelCoordArea specifies the bounds of a pixilated data object in pixel space.

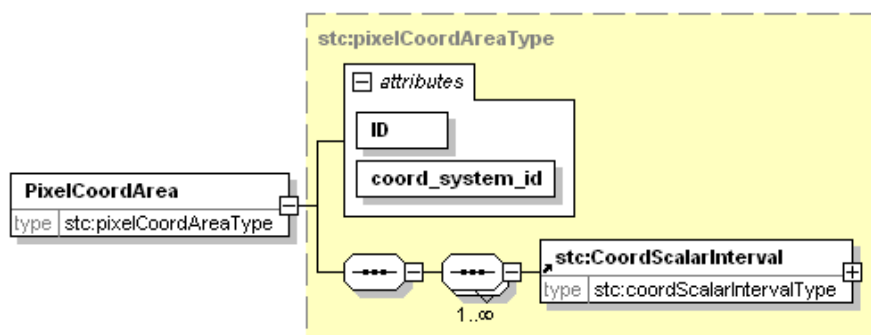

### 7.3 SpatialInterval

Spatial area is not only more complicated because it may be multi-dimensional by itself, but also because there are additional options: a Region (specified directly or in a file) or a Sphere (or Circle/Cone).

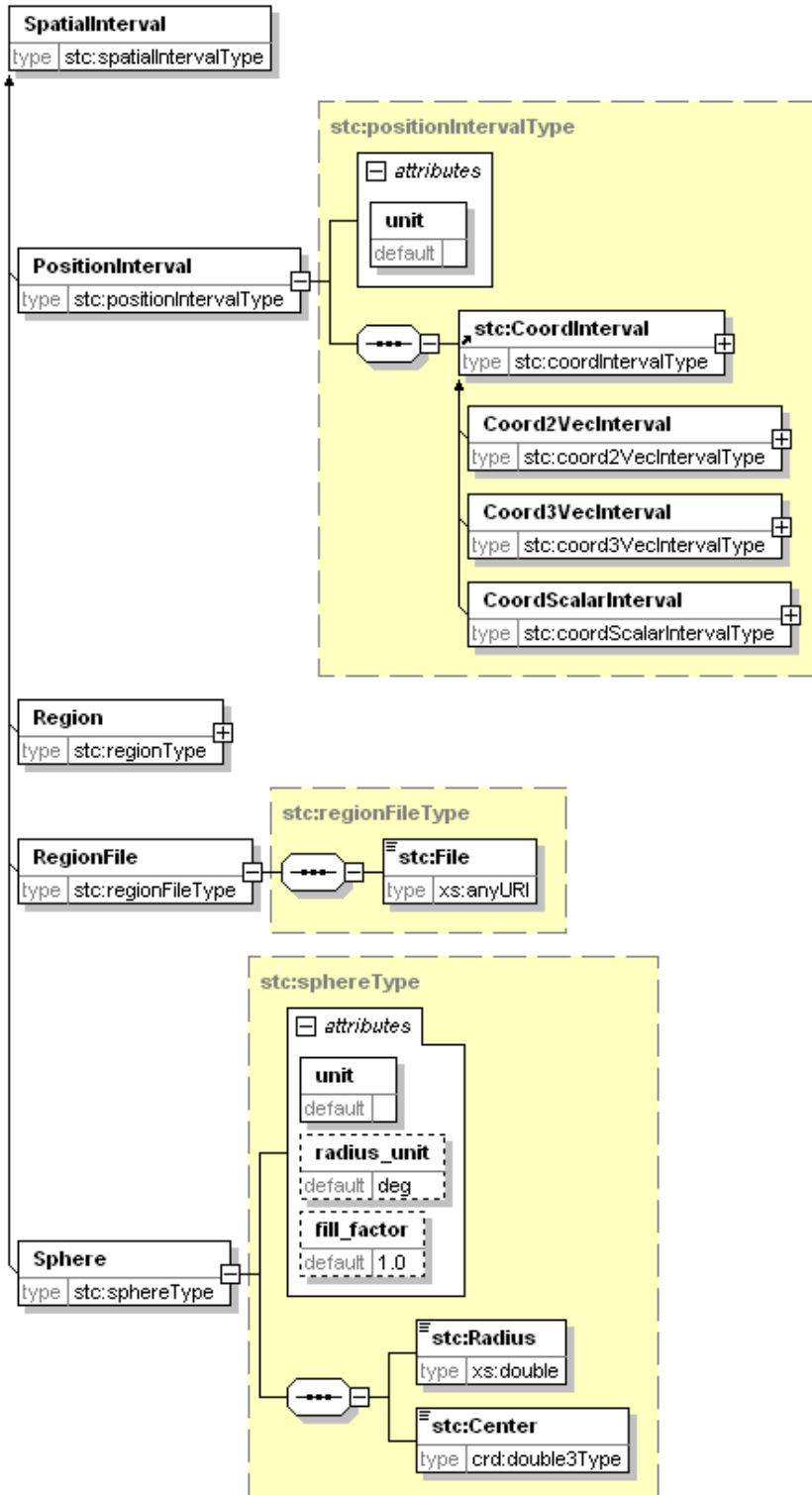

## 8 Coordinate interval

This is the most fundamental element type to specify an area; it may be 1-, 2-, or 3-dimensional. Bounds may or may not be included. Presence of only one of the bounds indicates a lower, respectively upper, limit.

### 8.1 CoordInterval

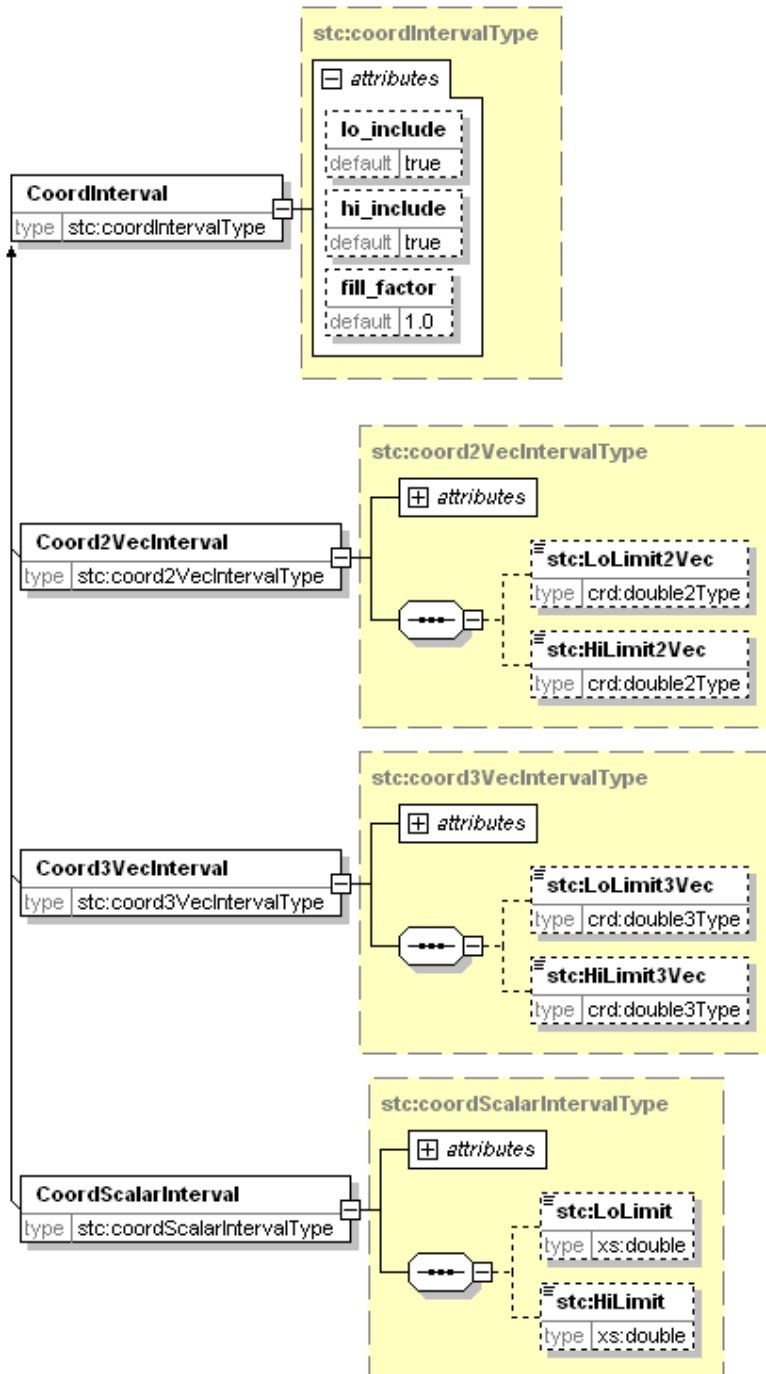

## 9 Spatial Region

Region is a specialized construct to address the needs for expressing common spatial shapes in a comprehensive way. A Region may consist of a Shape or be the result of an operation performed on one (Negation) or two (Union, Intersection) Regions.

### 9.1 Negation, Union, Intersection

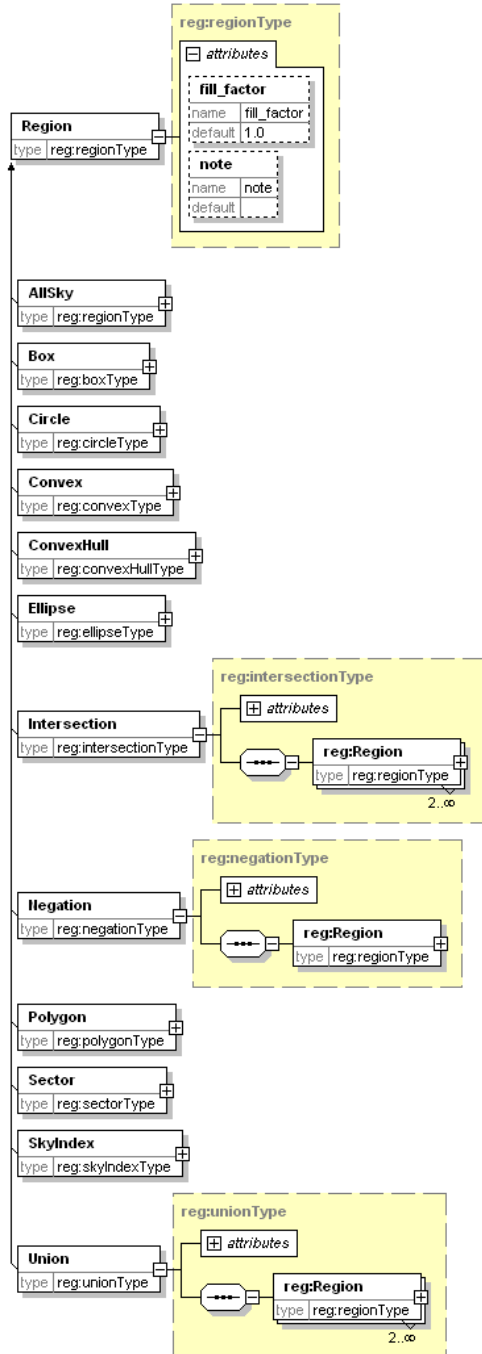

## 9.2 Allsky, Circle, and Ellipse

Allsky is an empty element (except for FillFactor) that is just a convenience.

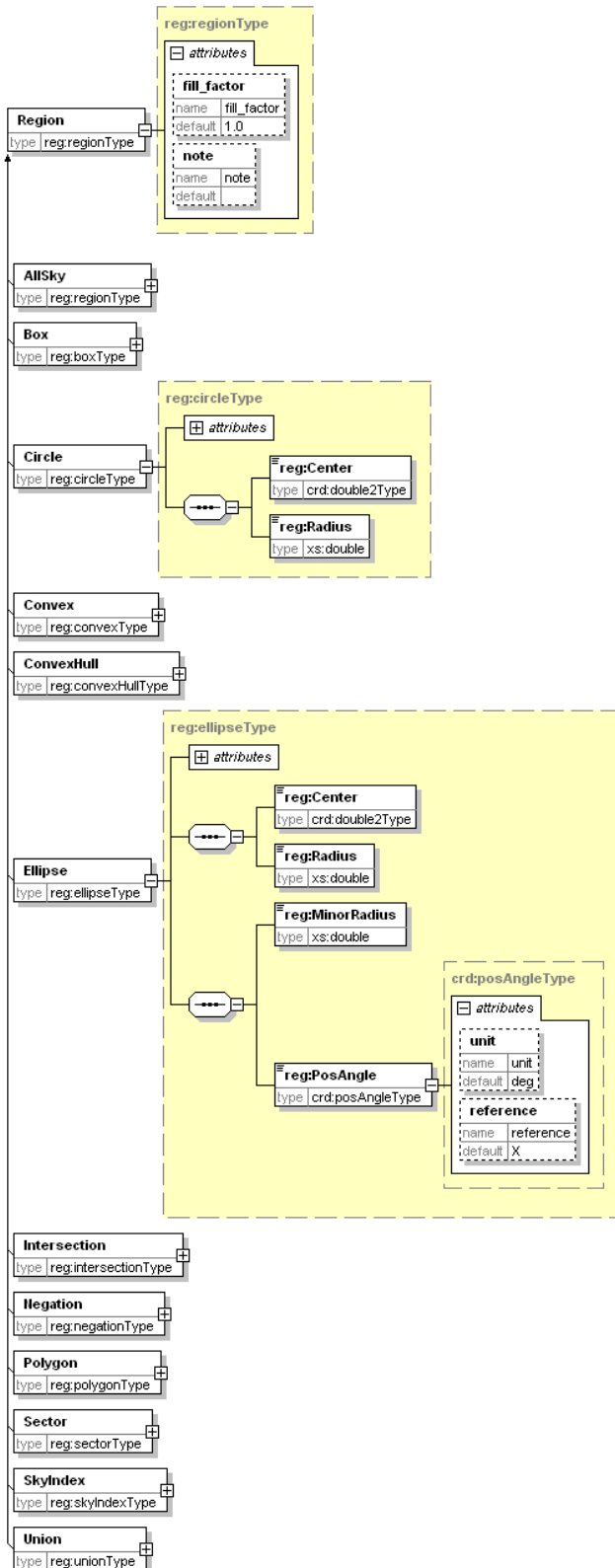

### 9.3 Polygon, Box, and Sector

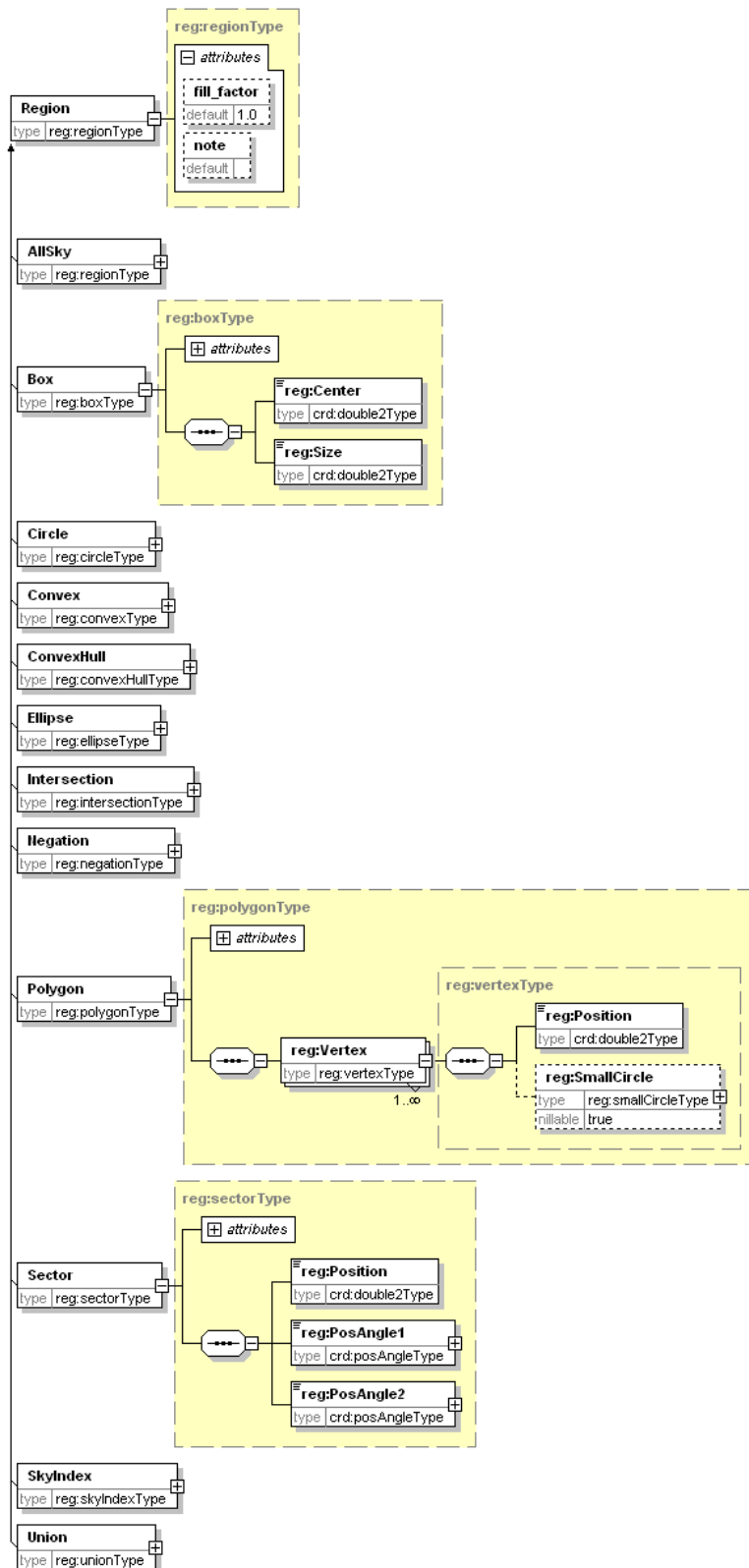

## 9.4 Convex and Convex Hull

Convex and ConvexHull operate on the Unit Sphere.

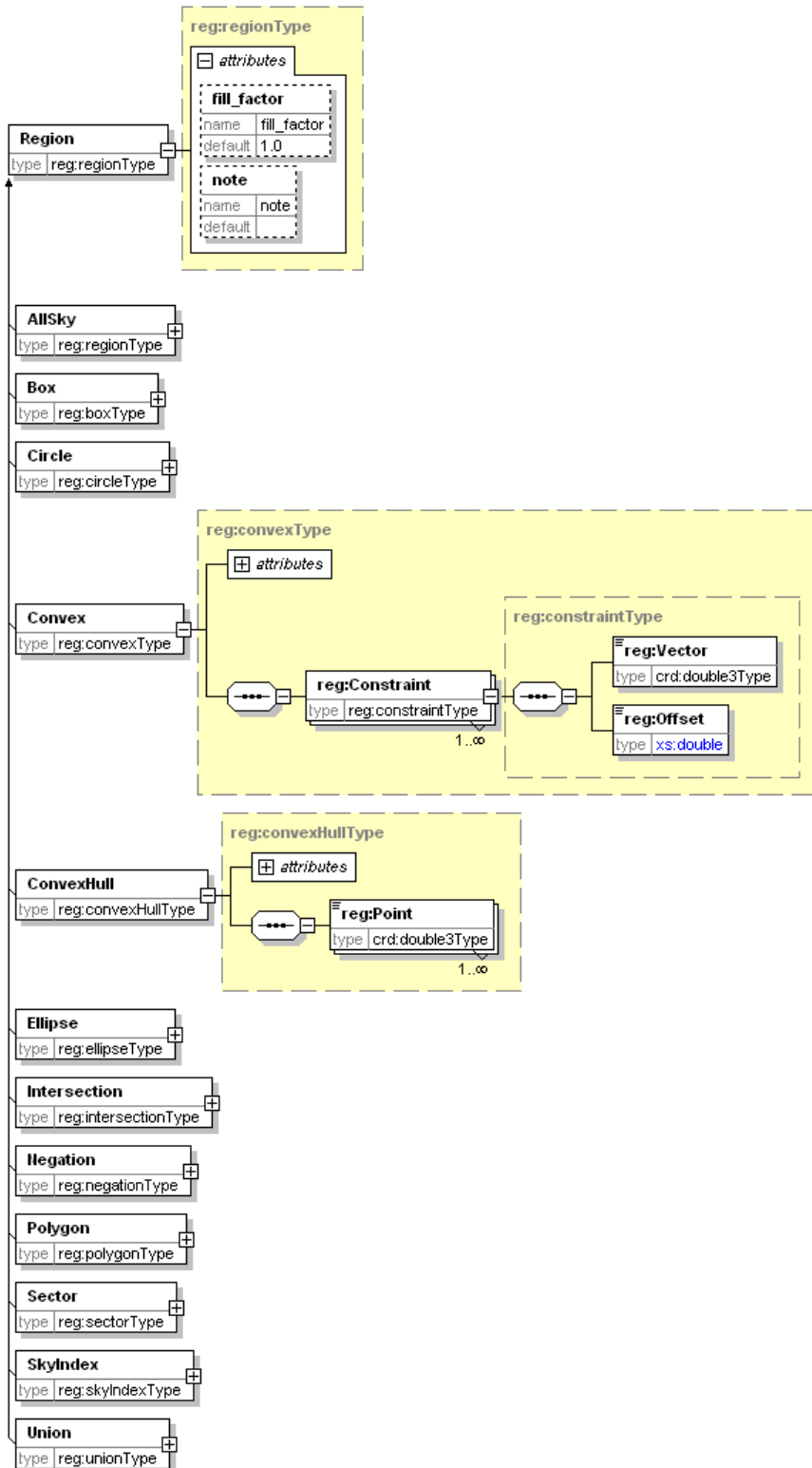

STC-X

## 10 Changes from Previous Versions

### References

A. H. Rots, *Space-Time Coordinate Metadata for the Virtual Observatory*,  
<http://www.ivoa.net/Documents/latest/STC.html>

A. H. Rots, *STC-S (LinearSTC): Space-Time Coordinate (STC) Metadata Linear String Implementation*  
<http://www.ivoa.net/Documents/latest/STC-S.html>